

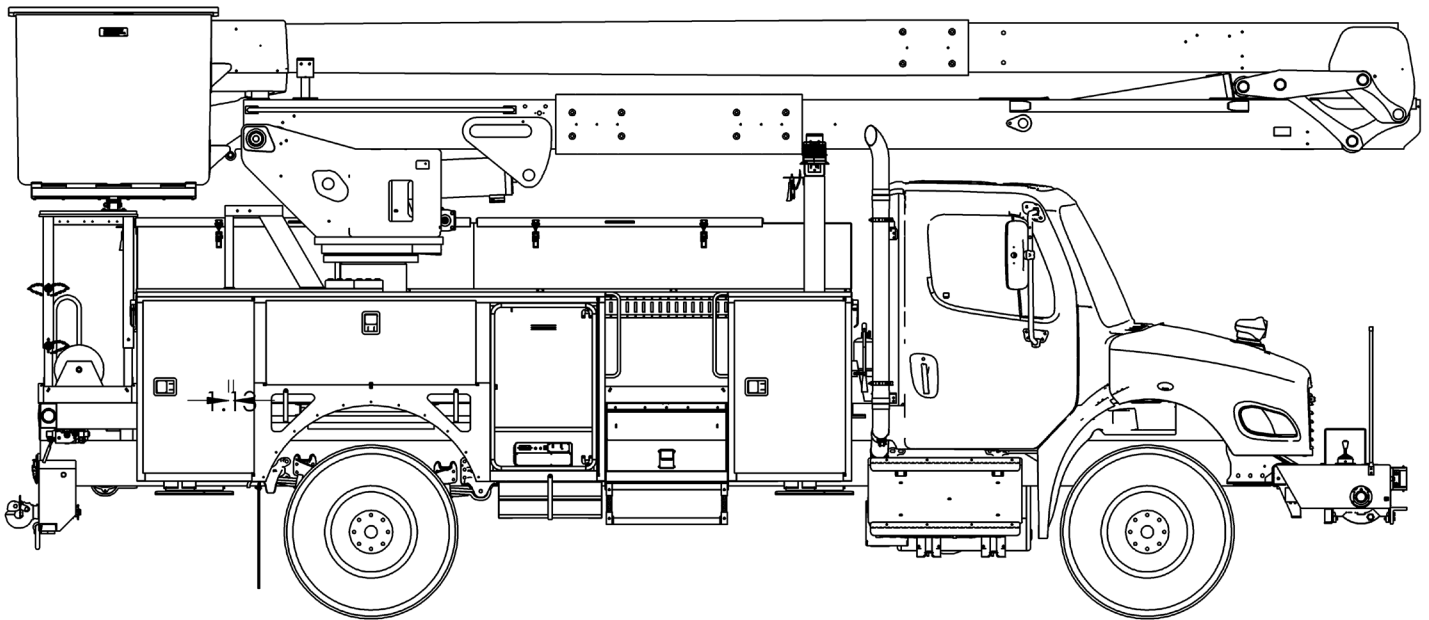

# TECH TIPS

SMART PTO START-UP PROCEDURE FOR CONVENTIONAL CHASSIS

NO. 208



**SERVICE CALL:**  
SMART PTO START-UP  
PROCEDURE FOR CONVENTIONAL  
CHASSIS



**MODEL(S):**  
ALL TEREX UTILITIES MODELS  
WITH SMART PTO INSTALLED



**TOOLS NEEDED:**  
NONE

TEREX UTILITIES TECHNICAL SUPPORT TEAM

PHONE: 1-844-TEREX4U (1-844-837-3948) | EMAIL: [UTILITIES.SERVICE@TEREX.COM](mailto:UTILITIES.SERVICE@TEREX.COM)



## **DANGER**

Failure to obey the instructions and safety rules in the appropriate Operator's Manual and Service Manual for your machine will result in death or serious injury.

Many of the hazards identified in the Operator's Manual are also safety hazards when maintenance and repair procedures are performed.

## **DO NOT PERFORM MAINTENANCE UNLESS:**

- ✓ You are trained and qualified to perform maintenance on this machine.
- ✓ You read, understand and obey:
  - manufacturer's instructions and safety rules
  - employer's safety rules and worksite regulations
  - applicable governmental regulations
- ✓ You have the appropriate tools, lifting equipment and a suitable workshop.

The information contained in this Tech Tip is a supplement to the Service Manual. Consult the appropriate Service Manual of your machine for safety rules and hazards.



TECH TIP 208 | RELEASED 07.25.2023 | VERSION 1.0  
©TEREX UTILITIES. ALL RIGHTS RESERVED

# CONTENTS

## TECH TIP#208

### TOC

4

| Engine off

| E-stop pulled out

**STEP 1 - STEP 2**

5

| Turn on PTO and E-PTO

**STEP 3 - STEP 5**

## STEP 1

If chassis is running, turn the ignition key OFF, then turn the key to ON without starting the engine. Confirm the truck is in neutral and the park brake is ON.



## STEP 2

Verify e-stop is pulled out on the Viatec system.

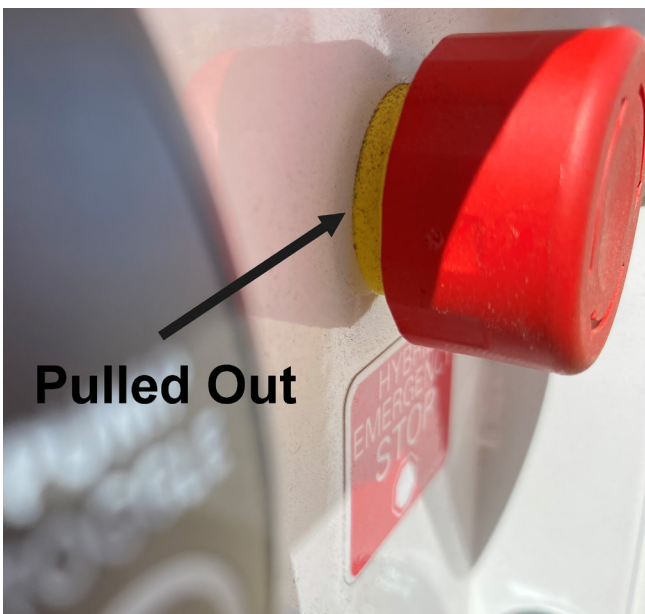

**FIGURE 3 - Allows Operation**



**FIGURE 4 - Operation Stopped**

### STEP 3

Verify the Viatic symbol with “detected” is on the bottom left-hand corner of the Terex Canview screen.

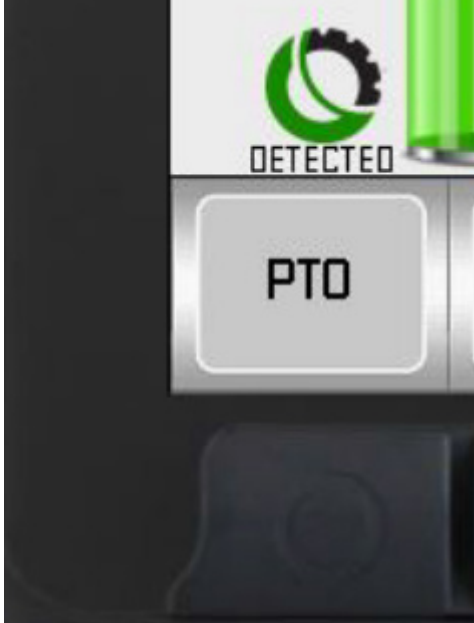

### STEP 4

Press the PTO button. The button should turn gray and “Detected” should change to “Allowed”.

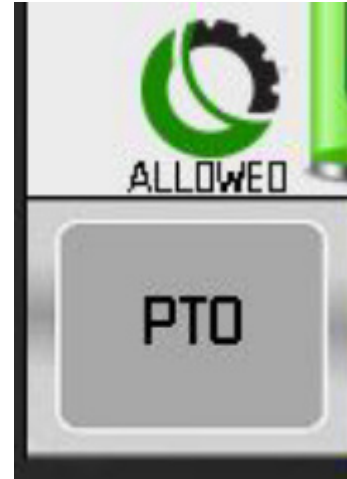

### STEP 5

Wait a few seconds after pressing the PTO button and then press the E-PTO button. It should turn yellow and then green. Green indicates the Smart PTO is ON and the pump is running.

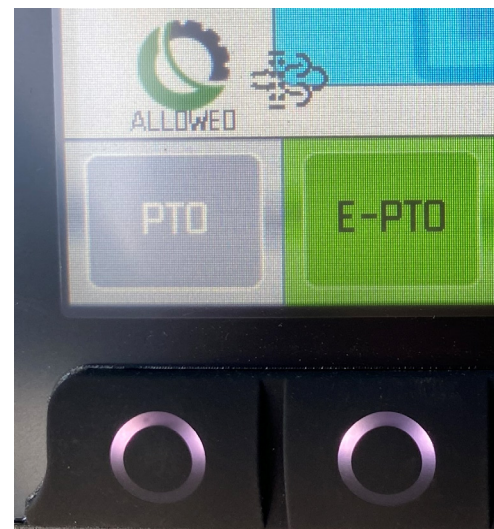
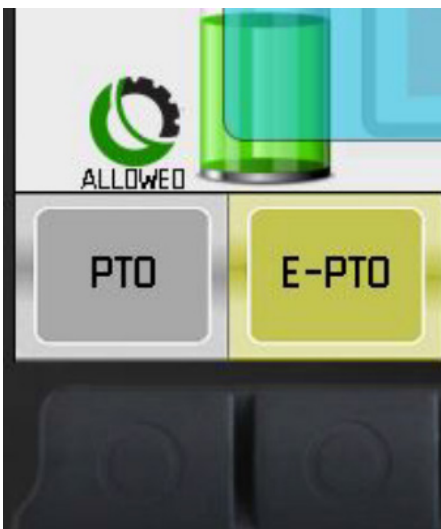

## STEP 6

The operator can also confirm the Smart PTO is ON and the pump is running by checking the LED bar on the Smart PTO unit.

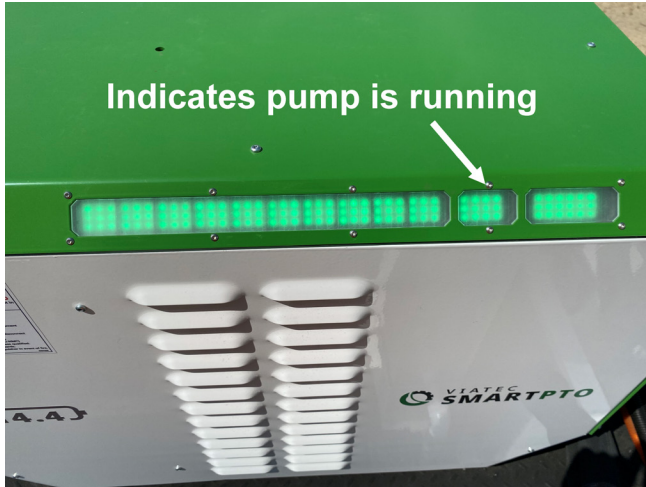

## STEP 7

If you have any questions call 1-844-TEREX4U (1-844-837-3948) or email [utilities.service@terex.com](mailto:utilities.service@terex.com)



FOR FURTHER ASSISTANCE,  
CONTACT THE TEREX UTILITIES TECHNICAL SUPPORT TEAM  
PHONE: **1-844-TEREX4U (1-844-837-3948)** | EMAIL: **[UTILITIES.SERVICE@TEREX.COM](mailto:UTILITIES.SERVICE@TEREX.COM)**

---